

Multi-Function Clamp System Model SEEM

USED ON 1.56" (40 mm) CENTER DISTANCE GRIDPLATES

Kurt fixtured monoblock clamp system works with all gridplates with M10 / M12 / M14 and M18 for "T" nuts per DIN 508. The clamp system is mounted through open construction with clamping actuation from top.

MULTI-FUNCTION CLAMP SYSTEM FEATURES:

- More clamp pressure than similar products
- More applications than other systems
- Allows upside down clamping

T-Nut through closed construction adjusts in table free sliding condition. Position fixation occurs simultaneous with clamp operation. T-Slot width from .39" (10 mm) through 1.56" (40 mm) using T-Nuts C' bored to fasten unit from bottom with socket screw and tapped key inside the clamp unit.

**NEW
from KURT**



Versatile Clamping System

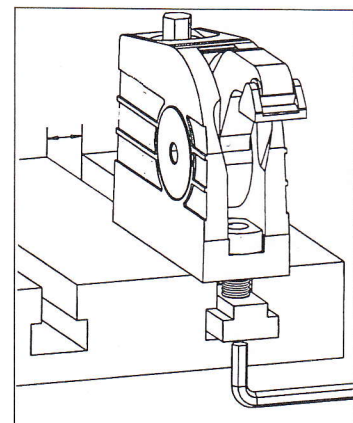
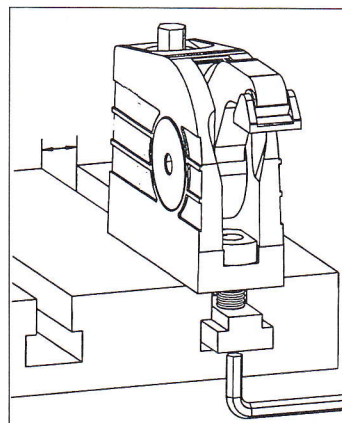
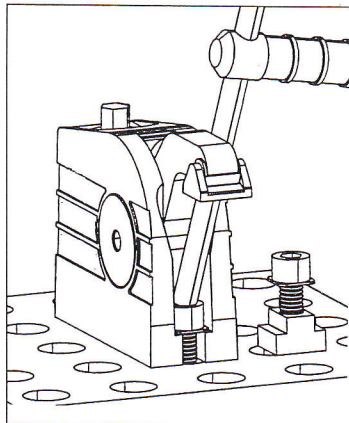

KIT - CLAMP UNITS - CLAMP ARM OPTIONS

Clamp Arm Length	Model SEE	Model SEM		Model SEEM
	Clamp Base Unit Order Number	Fixtured Clamp Tie down (bolt) Order No.		Multifunction Clamp Order Number
A	SEE 142	M10 M12	SEM142 SEM 242	Retrofit Arm (A) SEA 42
B	SEEL 267	M10 M12	SEML 167 SEML 267	Retrofit Arm (B) SEA 67
C	SEEL 3132	M10 M12	SEMEL 1132 SEMEL 2132	Retrofit Arm (C) SEA 132
	LIFT ARM			SEEM 62 using T-Nut Rail Table or T-Nut Max. arm extension 2.4" (62 mm)

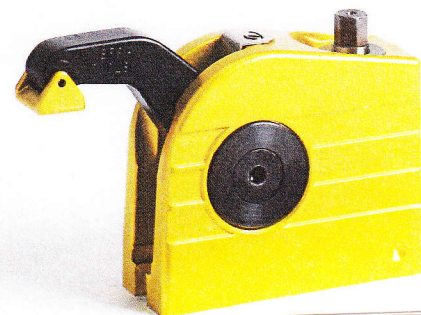

ISO 9001 Certified

FERRA TOOLS

Systemwerkzeuge GmbH

Tannenallee 14

21465 Reinbek

Tel: 040-73 17 55 Fax 040-73 17 59